



RUV API6D FORGED BODY BALL VALVE



FDR-2 Floating Ball Valve GDR-2 Trunnion Mounted Ball Valve

CAB-17-01

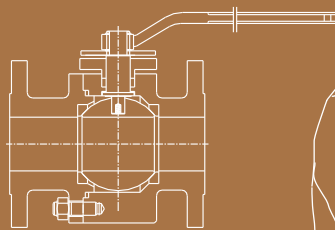
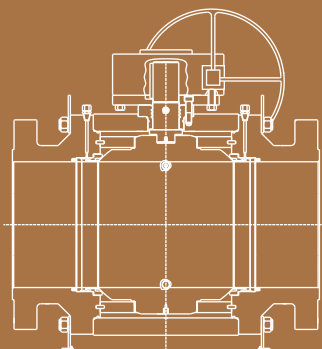

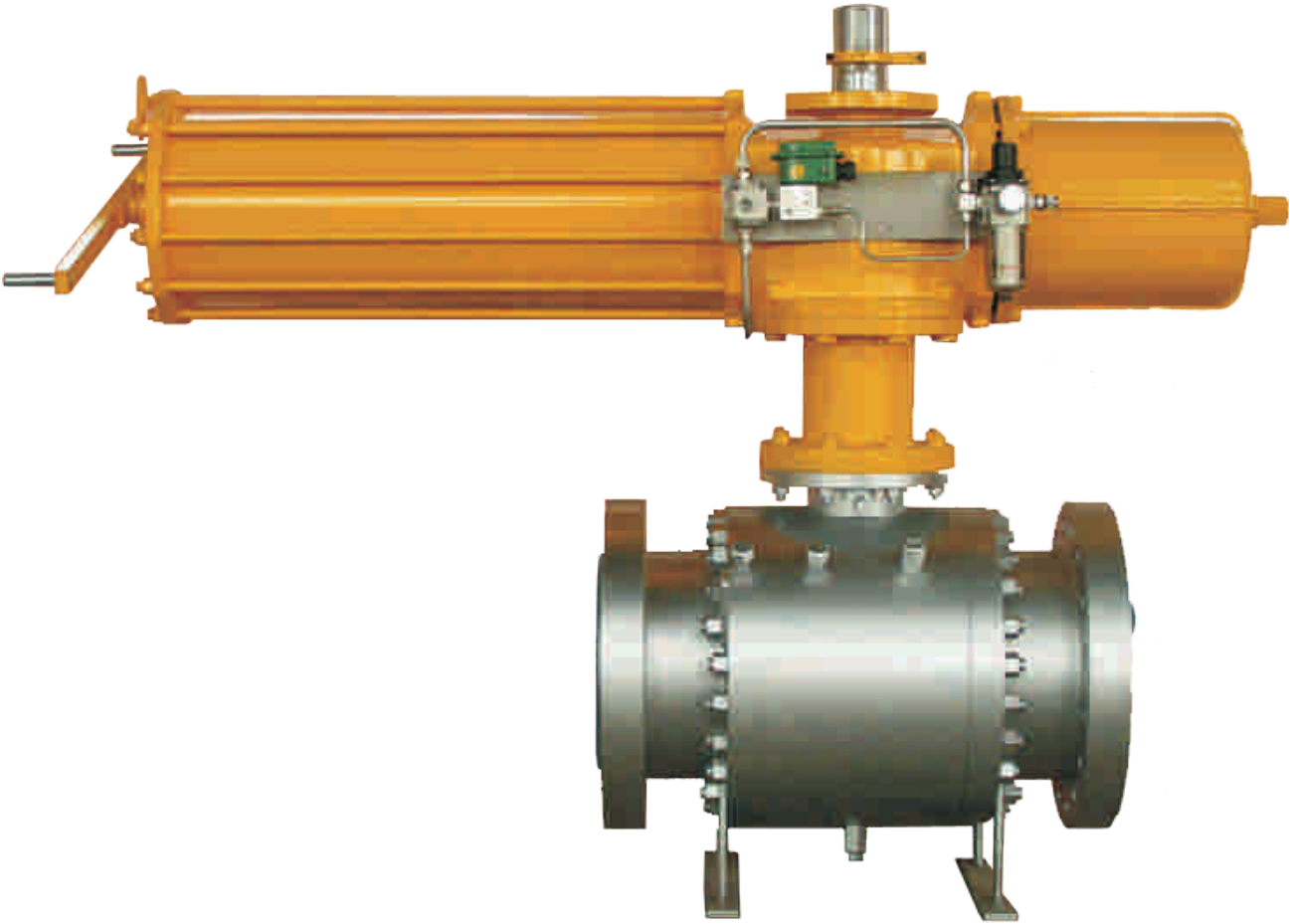

FORGED BODY BALL VALVE

Floating Ball Valve

Standard Page 2
Product Range Page 3
Feature Page 4
Dynamic drawing Page 5
Material Page 5
P-T Rating Page 6
Dimension Page 7

Trunnion Mounted Ball Valve

Feature Page 8
Dynamic drawing Page 11
Material Page 12
P-T Rating Page 13
Dynamic drawing Page 14
Dimension Page 15
Cv value and valve torque Page 17
Pipe size Page 18
Top works Page 19
Test Procedure Page 21
Fig. No. Page 22

Rocky Union is committed to enhancing our customers' working site safety, system stability, and convenient operations through our valve product offerings. Our diverse and innovative valves will have more safety design, longer working life and more reliable operation.

Located in the city with a more than forty years' history to make industrial valve, RUV has carried on the mature valve manufacturing tradition of Zigong city. By our advanced seat design and special workmanship, we are making high quality ball valve and through conduit gate valve, range from complete size and pressure for petroleum, chemical, and energy industrial use. To be a professional API6D valve company, we are making for reliability.

RUV BALL VALVE STANDARD

Rocky Union valves are designed, manufactured and tested in accordance with API, ANSI and ASME requirements. The following list contains the most important applicable standards. Rocky Union valves may be produced in accordance with other standards on request.

ANSI-American National Standard Institute

- ASME B 1.20.1 Pipe threads, general purpose
- ASME B 16.5 Steel pipe flanges and flanged fittings
- ASME B16.10 Face-to-face and end-to-end dimensions of ferrous valves.
- ASME B 16.25 Butt welding ends
- ASME B16.34 Steel valves-flanged and butt welding ends
- ASME B16.47 Larger diameter steel flange(26" ~ 60")
- ASME B31.3 Technics pipeline
- ASME Boiler and Pressure Vessel Code, Section VIII, Division 1, rules for construction of pressure vessel
- MESC SPE 76/001 Surface roughness degree of flange gasket interface
- MESC SPE 77/130 Ball Valve to API SPEC. 6D
- MESC SPE 77/302 Material Acceptance Requirements for Valves in General Service
- MESC SPE 77/315 Electroless Nickel Plating

British Standard

- BS 1503 Pressure-containing forged parts (including semi finished) specification
- BS 6755-2 Valve test, section 2: fire test requirement specification
- BS 5351 Industrial valve, shell thickness, and bore dimension
- BS 1560 End flange dimensions and Flange gasket facing
- BS 5146 Pressure test

ISO9001-International Organization for Standardization

- ISO9001 Quality systems-model for quality assurance in design, development, production, installation and servicing.
- ISO15156 Materials for use in H2S containing environment in oil & gas production.
- ISO 5211-1 Executive institution accessories of quarter-turn valves, section1: flange dimension
- ISO 5211-2 Executive institution accessories of quarter-turn valves, section2: capability character of flange and connector.
- ISO 5211-3 Executive institution accessories of quarter-turn valves, section3: the dimension of drive parts
- ISO 10479 Valve test: fire-proof test requirement

API-American Petroleum Institute

- API 6A Specification for wellhead valves
- API 6D Specification for pipeline valves
- API 6FA Specification for fire testing of valves
- API 607 Fire test for soft seated quarter-turn valves
- API Q1 Quality program
- API 5B EUE External upset tubing threads

MSS-Manufacturers Standardization Society

- MSS SP-6 Standard finishes for contact faces of pipe flanges and connecting-end flanges of valves and fittings.
- MSS SP-25 Standard marking system for valves, fittings, flanges and unions.
- MSS SP-55 Quality standard for steel castings.
- MSS SP-45 Bypass, and drain connections standard
- MSS SP-53 Cast steel quality standard of valve, flange, fitting and pipeline accessories -- Magnetic-particle testing
- MSS SP-54 Cast steel quality standard of valve, flange, fitting and pipeline accessories ---Radiographic testing
- MSS SP-93 Cast steel and forged steel quality standard of valve, flange, fitting and pipeline accessories ---Liquid Penetrant Testing

- PrEN 12116 Industry valve, executive institution accessories of quarter-turn valves
- DEP 31.38.01.11-GEN Standard of pipeline
- DEP 31.40.70.30-GEN Quarter-turn open/close executive institution
- DEP 32.36.01.17-GEN Control valves' choice, specification and standard

NACE-National Association of Corrosion Engineers

- MR0175 Sulfide stress cracking resistant metallic materials for oil field equipment (Superseded by ISO15156)

RUV BALL VALVE PRODUCTS RANGE

● VALVE BALL SUPPORTING

Floating ball valve		Trunnion Mounted ball valve	
Size	1/2 " to 8 "	Size	2 " to 42 "
Pressure	150# , 300#	Pressure	150#/300#/600# 900#/1500#/2500#
Temperature	-46°C to 500°C	Temperature	-46°C to 500°C

● VALVE SEALING METHOD

Soft seated ball valve		Metal to metal seated ball valve	
Size	1/2 " to 42 "	Size	2 " to 24 "
Pressure	150#/300#/600# 900#/1500#/2500#	Pressure	150#/300#/600# 900#/1500#/2500#
Temperature	-46°C to 150°C	Temperature	-46°C to 500°C

● VALVE BODY CONNECTION

Bolted body		Fully welded body	
Size	1/2 " to 42 "	Size	6 " to 48 "
Pressure	150#/300#/600# 900#/1500#/2500#	Pressure	300#/600# 900#/1500#
Temperature	-46°C to 500°C	Temperature	-46°C to 150°C

● VALVE BALL ENTRY THE BODY TYPE

Side entry ball valve		Top entry ball valve	
Size	1/2 " to 42 "	Size	2 " to 24 "
Pressure	150#/300#/600# 900#/1500#	Pressure	150#/300#/600# 900#/1500#
Temperature	-46°C to 500°C	Temperature	-46°C to 500°C

● VALVE OPERATION

Handle/Lever	Gear Box
Electric actuation	Hydraulic actuation
Pneumatic actuation	Gas Over Oil actuation

RUV valves can be configured to match the general working conditions of our customers as shown above. And the following descriptions are for valves that are most commonly used in the industry. Upon request RUV can manufacture valves to meet any customer specifications that may be required.

FDR-2 FLOATING BALL VALVE FEATURE

ROCKY UNION FDR TYPE FLOATING BALL VALVE

Content	Specification
General design standard	API6D/API608
Pressure-temperature rating	ASME B16.34
Face to face dimensions	ASME B16.10
Flange type and dimensions	ASME B16.5
Butt-welded end	ASME B16.25
Inspection and test	API6D/API598



FLOATING BALL VALVE FEATURES

● BLOW OUT-PROOF STEM CONSTRUCTION

The lower end of stem is terraced and is installed from the inside of the valve body. This construction insures a blow out proof stem and metal to metal seal in case of fire.

● ANTISTATIC DESIGN

During operation of valve, static electricity may accumulate on the ball. The special antistatic device can discharge the static electricity during opening and closing of the valve.

● FIRE-SAFE DESIGN: API607/API6FA

Each possible leaking part between Ball and Body, Middle flange, Stem and body are designed for metal to metal contact which conforms to the fire-proof requirements of API6FA and API 607. In case of extreme fire-proof conditions, the packing and gasket material shall be flexible graphite to insure zero leakage.

● LOCKING DEVICE

The valve is equipped with locking holes for the lever in the full open and full closed position, to prevent accidental opening and closing of the valve.

● MIDDLE FLANGE WITH NO LEAKAGE DESIGN

(Body and Cap connection)
Body and Cap connection are sealed by gaskets. To prevent leakage from fire, high temperature or vibrations, metal to metal sealing between the body and cap is maintained.

● WRENCH WITH VALVE OPEN/CLOSE INDICATION

When the handle(lever) is on the same horizontal line with the pipe, this indicates the valve is at open position. When the handle(lever) is on the vertical line with the pipe, this indicates the valve is at closed position.

● ADVANCED AND EXCLUSIVE SEAT DESIGN

With many years of Ball Valve manufacturing experience and advanced technology from abroad, the cone sealing surface developed, makes the sealing more reliable. Our designs are available with various types of seat materials that offer low friction and low operational torque.

FDR-2 FLOATING BALL VALVE DYNAMIC DRAWING

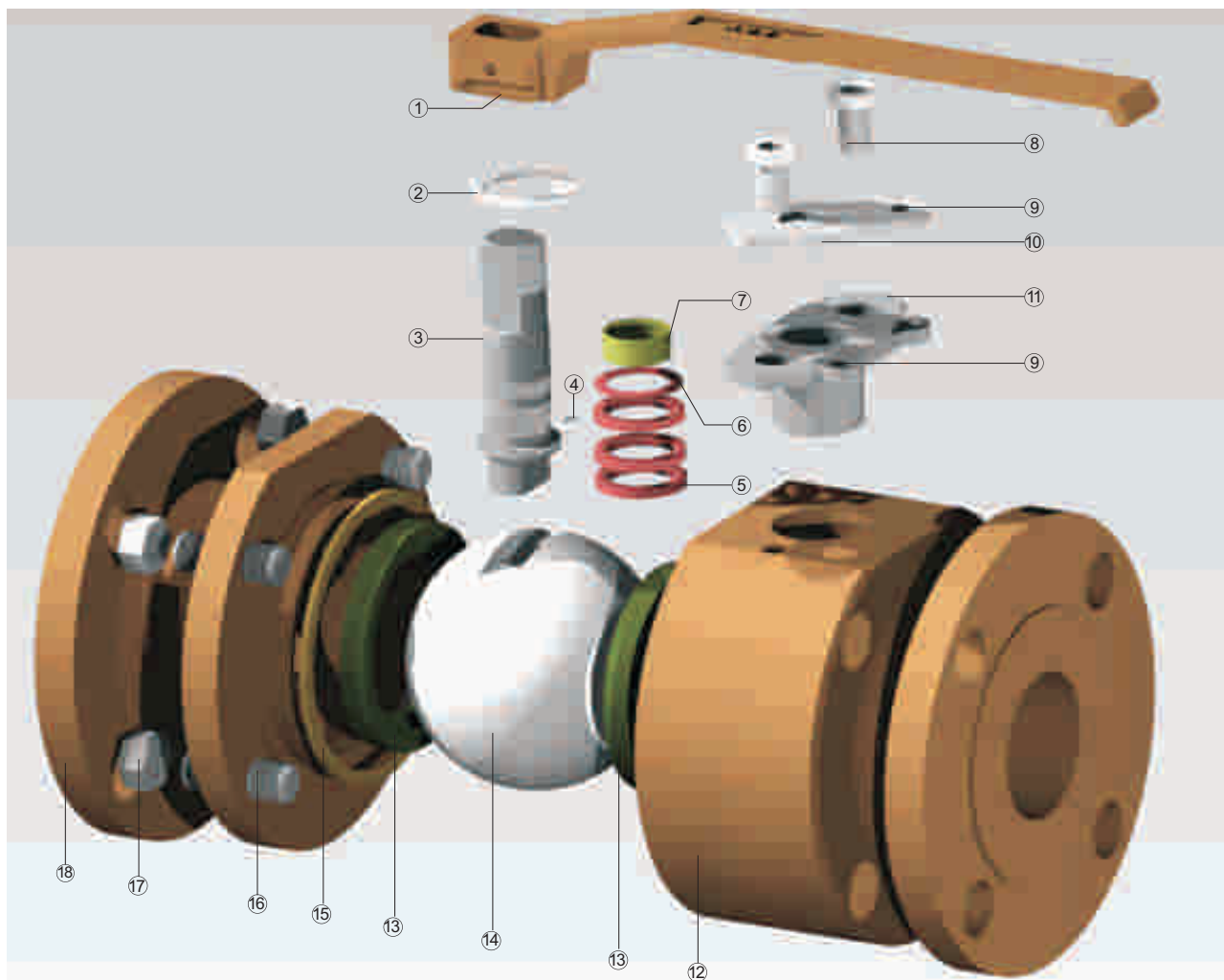

Item	Part Name	Item	Part Name	Item	Part Name
1	Lever	7	Stem bearing	13	Seat
2	Snap ring	8	Gland bolt	14	Ball
3	Stem	9	Locking hole	15	Gasket
4	Antistatic spring	10	Limited plate	16	Bolt
5	Thrust bearing	11	Packing gland	17	Nut
6	Packing	12	Body	18	Bonnet

Part	CS Series	Sulfur-proof Series	SS. Series NACE		LCC, LBB Series
Body	A105	A105	F304, F304L	F316, F316L	LF2
Ball	A105+HCR/ENP	A105+ENP	A182-F304, F304L	A182-F316, F316L	A182-F304+HCR
Stem	A182-F6A	ANSI 4140	A182-F304, F304L	A182-F316, F316L	A182-F304
Seat Insert	PTFE (standard) /PPL(high temperature)/PEEK/EPDM/VITON/DEVLON				
Packing	PTFE / PPL/Graphite				
Gasket	PTFE / PPL/SS+Graphite				
Bearing	PTFE / PPL				
Stud	A193-B7	A193-B7M	A193-B8	A193-B8M	A320-L7/L7M
Nut	A194-2H	A194-2HM	A194-8	A194-8M	A194-7/7M

FDR-2 FLOATING BALL VALVE P-T RATING

PRESSURE-TEMPERATURE RATING

The following table indicates rated values of temperature and pressure for main materials of valves. These valves are determined according to American standard ASME/ANSI B16.34

Temp		Max. Working Pressure											
		150Lb		300Lb		400Lb		600Lb		900Lb		1500Lb	
°F	°C	WCB,LCB	CF8M	WCB,LCB	CF8M	WCB,LCB	CF8M	WCB,LCB	CF8M	WCB,LCB	CF8M	WCB,LCB	CF8M
Up to	Up to	bar	bar	bar	bar	bar	bar	bar	bar	bar	bar	bar	bar
100	38	19.7	19	51	49.6	68.3	66.2	102	99.3	153.1	148.9	255.5	248.2
200	93	17.9	16.5	46.5	42.7	62.1	56.9	93.1	85.5	139.6	128.2	232.7	213.4
300	149	15.9	14.8	45.2	38.6	60.3	51.4	90.7	77.2	135.8	115.8	226.1	192.7
400	204	13.8	13.4	43.8	35.5	58.3	47.2	87.6	71	131	106.2	218.6	177.2
500	264	11.7	11.7	41.4	33.1	55.2	43.8	82.7	65.8	123.8	98.9	206.5	164.8

The RUV soft seated trunnion mounted ball valve P-T rating is not only related to the body material, but also related to the material of seat, packing and gasket. Sealing material is made of macromolecule, asbestos or rubber. And the selection of sealing material is depended upon the medium of the valve, valve working temperature, pressure and velocity of flow. As the P-T rating is varied on different valve working conditions, the following P-T rating value is calculated out by stable valve working condition.

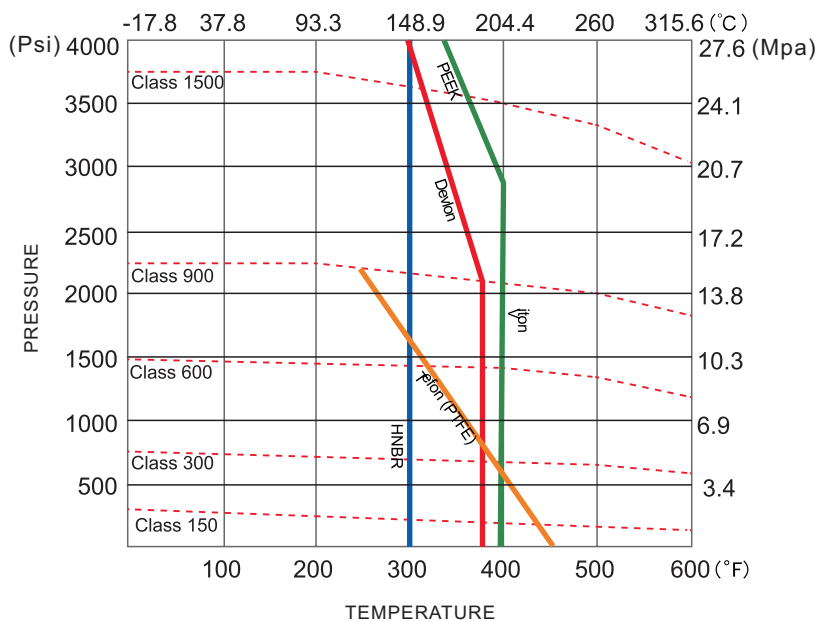

LOW TEMPERATURE LIMITS

Body Material	°F	°C
A105	-20	-29
LF2	-50	-46
F316	-320	-196

Seal Material	°F	°C
Teflon(PTFE)	-50	-100
Viton	-20	-29
Peek	-50	-100

Seal Material	°F	°C
Devlon	-50	-40
HNBR	-50	-46

FDR-2 FLOATING BALL VALVE DIMENSIONS

FLOATING BALL VALVE DIMENSIONS

FULL BORE TYPE

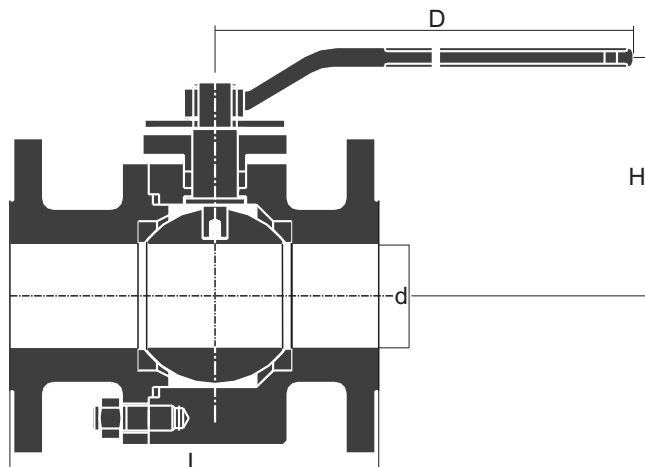

● **CLASS 150 Dimensions**

DN	1/2"	3/4"	1"	1 1/2"	2"	2 1/2"	3"	4"	5"	6"	8"
d	13	19	25	38	49	62	74	100	125	150	201
L	108	117	127	165	178	190	203	229	356	394	457
H	63	75	95	115	120	155	165	200	220	295	355
D	130	130	160	230	230	380	400	450	700	750	900
Wt(Kg)	3	4.5	7.5	11	13	16	23	35	55	75	205

● **CLASS 300 Dimensions**

DN	1/2"	3/4"	1"	1 1/2"	2"	2 1/2"	3"	4"	5"	6"	8"
d	13	19	25	38	49	62	74	100	125	150	201
L	140	152	165	191	216	241	283	305	381	403	502
H	63	75	95	115	120	155	165	200	220	295	355
D	130	130	160	230	230	400	400	600	700	750	900
Wt(Kg)	4.5	7.5	10	12.5	14.5	20	27	41.5	80	110	230

● **CLASS 600 Dimensions**

DN	1/2"	3/4"	1"	1 1/2"
d	13	19	25	38
L (RF)	165	190	216	241
H	105	108	130	135
D	160	160	230	230
Wt (Kg)	5	8.5	12	14

● **CLASS 900/1500 Dimensions**

DN	1/2"	3/4"	1"	1 1/2"
d	13	19	25	38
L (RF)	216	229	254	305
H	115	115	122	157
D	160	230	230	400
Wt (Kg)	8	12	15	18

Cv value











Right chart is the flow ratio of floating ball.

Cv indicates the gallons of water at temperature +60°F flowing through the valve bore in pressure differential down 1Lbs /Inch² (0.0068694757 Mpa).

Cv			
Specification	Inch	Metric	Full Bore
1/2"	15		25
3/4"	20		50
1"	25		100
1 1/2"	40		270
2"	50	165	490
2 1/2"	65	270	950
3"	80	350	1160
4"	100	550	2200
5"	125	670	3800
6"	150	765	5100
8"	200	1890	9300
10"	250	3900	

GDR-2 TRUNNION MOUNTED BALL VALVE FEATURE

FUNCTIONS & FEATURES

-  Draining
-  Fire safe
-  Safe release
-  Reliable seal
-  Special seat
-  Cleaning pipe
-  Emergency seal
-  Extended stem
-  Reliable operation
-  Bonnet combined seal
-  Double block & bleed
-  Various operations
-  Various end connections
-  Diversity of body materials
-  Diversity of seat materials
-  Bearing pipe stress safety
-  Various kinds of control systems



Pressure: 150#, 300#, 600#,
 900#, 1500#, 2500#
 Size: 2"-42"
 Working Medium: Gas, Oil, Steam,
 Water, etc
 Working Temperature
 Range: -101°C to 427°C

GDR-2 TRUNNION MOUNTED BALL VALVE FEATURE



ROCKY UNION GDR TYPE TRUNNION MOUNTED BALL VALVE

Content	Specification
General design standard	API6D
Pressure-temperature rating	ASME B16.34
Face to face dimensions	ASME B16.10
End Flange	ASME B16.5 ANSI B16.47
Butt-welded end	ASME B16.25
Inspection and test	API6D/API598

DESIGN FEATURE

UP STREAM SEALING TWO-WAY VALVE

RUV trunnion mounted ball valve has two seats on both side. Each seat has springs loaded and make seat insert contact the ball surface for sealing. So the valve is bi-directional sealing, and no limitation for installation.

FIRE-SAFE DESIGN API607/API6FA

When the seat inserts are softened and burnt in case of the fire or unusual temperature increase, the seat retainer, under the duty of the spring, will touch with the ball and form a metal-to-metal contact, which can prevent internal leak. Meanwhile, the middle flange and the upper part and lower part of the stem will form a metal-to-metal contact which can prevent external leak and conform to API6FA or API607.



Seat ring Seat insert Ball

Valve in normal working condition

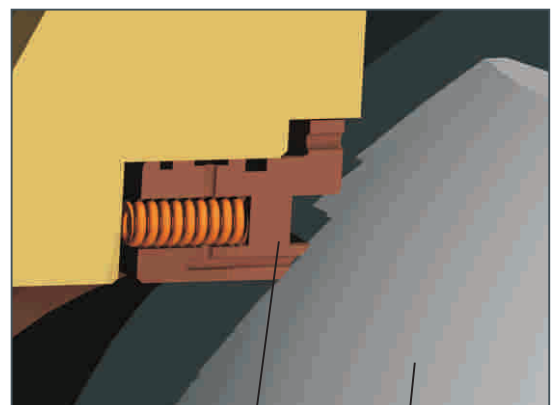

Seat ring Ball

Valve after fire

GDR-2 TRUNNION MOUNTED BALL VALVE FEATURE



VALVE CAVITY PRESSURE AUTOMATIC RELIEF

When the body cavity pressure exceeds the seat springs pressure by the thermal expansion of the fluid trapped in valve cavity, automatic pressure relief will occur by relieving the body cavity pressure past the downstream seat.

Until an equilibrium, seat ring will move back to contact the ball surface as a "Piston Effect" seat.

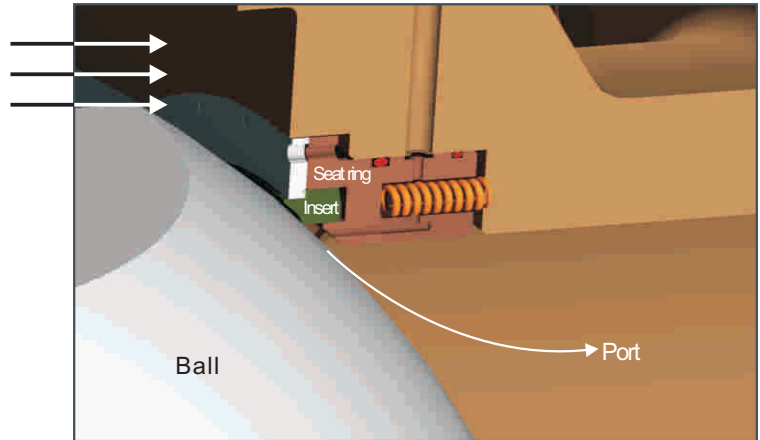

STEM AND SEAT EMERGENCY SEALANT INJECTION

The seat ring and the valve stem have a special grease injection valve. In case of the leakage, the grease will be injected to the valve ball surface and to the stem room, creates a temporary sealing.

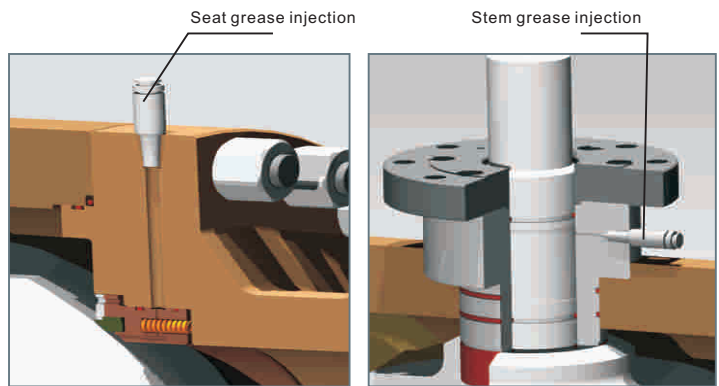

DOUBLE BLOCK AND BLEED DBB

The trapped cavity pressure can bleed out by vent fitting or drain plug when the valve is in fully open or fully closed position. The fluid is intercepted by seats of up stream and down stream side. So, the stem packing or O-ring may be replaced under working pressure. Each seat works independently assuring tight seal against ball on both upstream and downstream side.

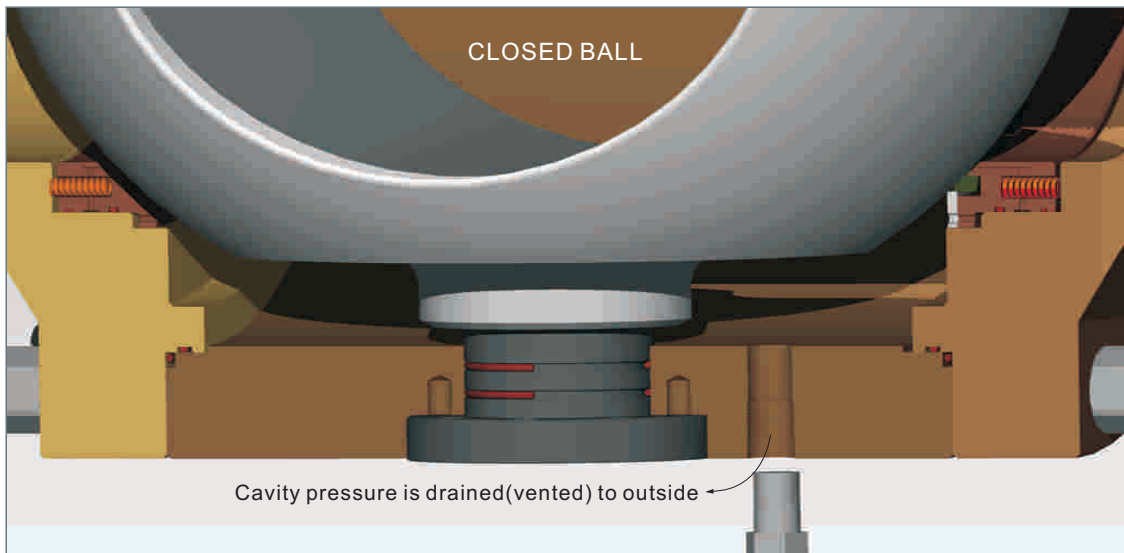

GDR-2 TRUNNION MOUNTED BALL VALVE DYNAMIC DRAWING

**ROCKY UNION GDR-2 TYPE
API6D THREE PIECES FORGED BODY TRUNNION MOUNTED BALL VALVE
SIZE 2" - 16" , PRESSURE 150# TO 2500#**

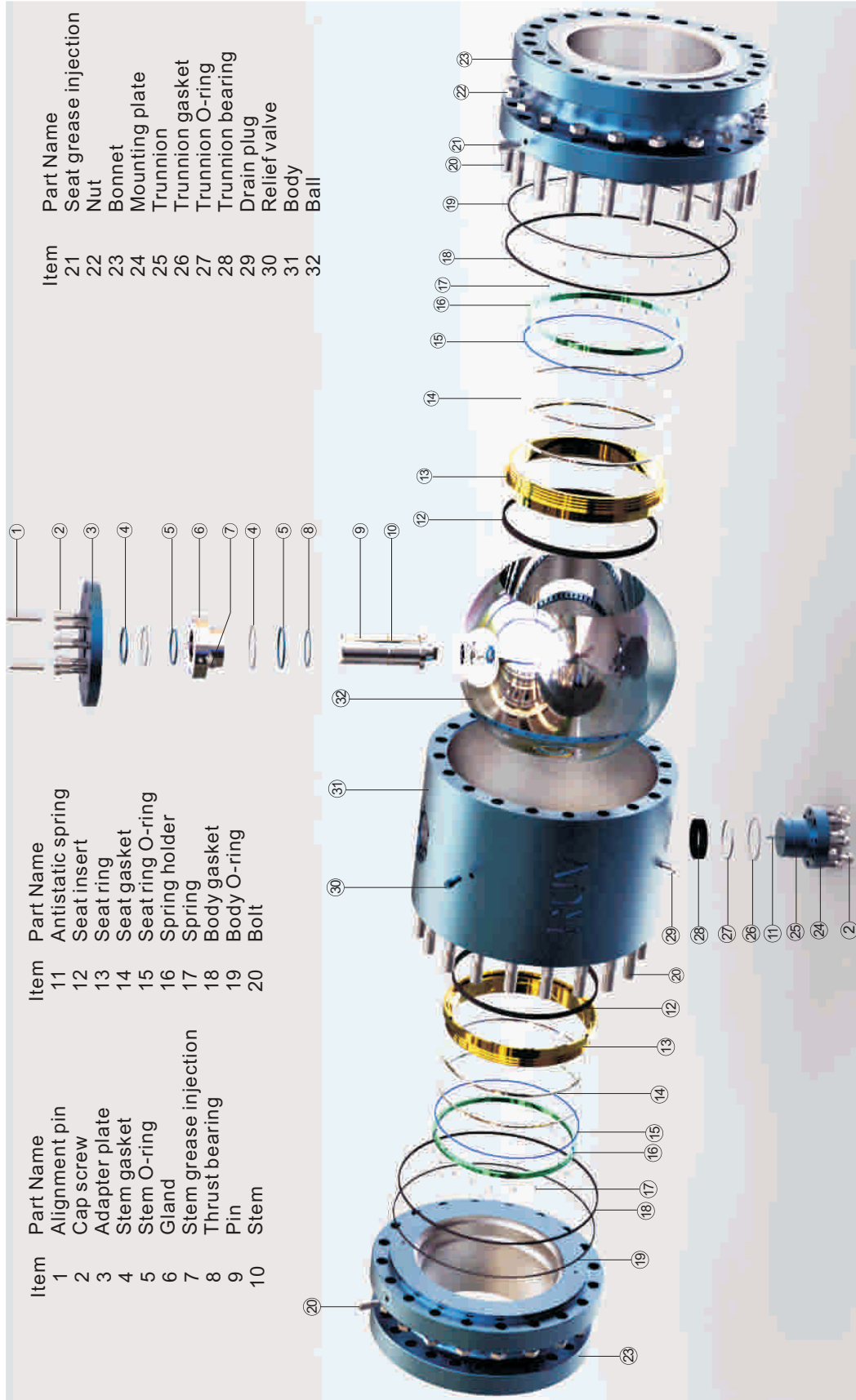

Item	Part Name
1	Alignment pin
2	Cap screw
3	Adapter plate
4	Stem gasket
5	Stem O-ring
6	Gland
7	Stem grease injection
8	Thrust bearing
9	Pin
10	Stem

Item	Part Name
11	Antistatic spring
12	Seat insert
13	Seat ring
14	Seat gasket
15	Seat ring O-ring
16	Spring holder
17	Spring
18	Body gasket
19	Body O-ring
20	Bolt

Item	Part Name
21	Seat grease injection
22	Nut
23	Bonnet
24	Mounting plate
25	Trunnion
26	Trunnion gasket
27	Trunnion O-ring
28	Trunnion bearing
29	Drain plug
30	Relief valve
31	Body
32	Ball

GDR-2 TRUNNION MOUNTED BALL VALVE MATERIALS

● **MATERIALS FOR MAIN PARTS**

Parts	C.S Series	Sufur-Proof Series	S.S Series		LF2 Series
Body	A105	A105	A182 F304/F304L	A182 F316/F316L	A350 LF2
	A105	A105	A182 F304/F304L	A182 F316/F316L	A350 LF2
Packing Gland	A105	A105N	A182 F304/F304L	A182 F316/F316L	A182-F304
Ball	A105+HCr	A105+ENP	A182 F304/F304L+HCr	A182 F316/F316L+HCr	A182-F304+HCr
Stem	A182-F6a	A182-410+ENP	A182-F304,F304L	A182-F316,F316L	A182-F304
Seat Insert	PTFE/PPL/NYLON/VITON/PEEK/EPDM/DEVLON				
Seat Retainer	A105+Zn	A105+ENP	A182-F304,F304L	A182-F316,F316L	A182-F304
Packing	PTFE/PPL/Graphite				
Gasket	PTFE/PPL/SS+Graphite				
Bearing	PTFE/PPL				
Spring	316SS/Inconel X-750/17-4PH/35-CrMo				
Stud	A193-B7	A193-B7M	A193-B8	A193-B8M	A320-L7/L7M
Nut	A194-2H	A194-2HM	A194-8	A194-8M	A194-7/7M

REMARKS:

1. All materials conform to ASTM standard.
2. Materials above conform to general standard. We can apply other materials according to valve working condition or customer's requirement. We also reserve the rights to improve the valve material according to relating standard.
3. Zn-Galvanized ENP-Electroless Nickel Plated Hcr-Electroless Hard Chrome Plated
4. Under -30°C (-22°F), working condition, the valve stem need to be extended.
5. For NACE working requirements, spring strength ≤HRC28, body hardness ≤HRC22.

GDR-2 TRUNNION MOUNTED BALL VALVE P-T RATING

PRESSURE-TEMPERATURE RATING

The following table indicates rated values of temperature and pressure for main materials of valves. These valves are determined according to American standard ASME/ANSI B16.34

Temp		Max. Working Pressure											
		150Lb		300Lb		400Lb		600Lb		900Lb		1500Lb	
°F	°C	A105,LF2	F316	A105,LF2	F316	A105,LF2	F316	A105,LF2	F316	A105,LF2	F316	A105,LF2	F316
Up to	Up to	bar	bar	bar	bar	bar	bar	bar	bar	bar	bar	bar	bar
100	38	19.7	19	51	49.6	68.3	66.2	102	99.3	153.1	148.9	255.5	248.2
200	93	17.9	16.5	46.5	42.7	62.1	56.9	93.1	85.5	139.6	128.2	232.7	213.4
300	149	15.9	14.8	45.2	38.6	60.3	51.4	90.7	77.2	135.8	115.8	226.1	192.7
400	204	13.8	13.4	43.8	35.5	58.3	47.2	87.6	71	131	106.2	218.6	177.2
500	264	11.7	11.7	41.4	33.1	55.2	43.8	82.7	65.8	123.8	98.9	206.5	164.8

The RUV soft seated trunnion mounted ball valve P-T rating is not only related to the body material, but also related to the material of seat, packing and gasket. Sealing material is made of macromolecule, asbestos or rubber. And the selection of sealing material is depended upon the medium of the valve, valve working temperature, pressure and velocity of flow. As the P-T rating is varied on different valve working conditions, the following P-T rating value is calculated out by stable valve working condition.

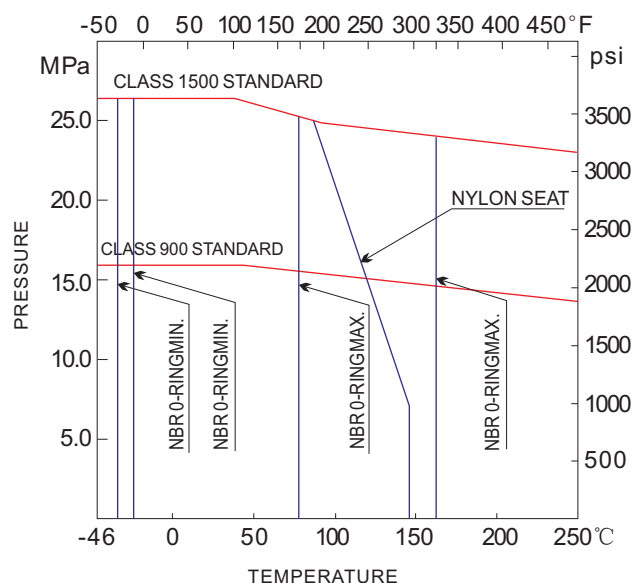
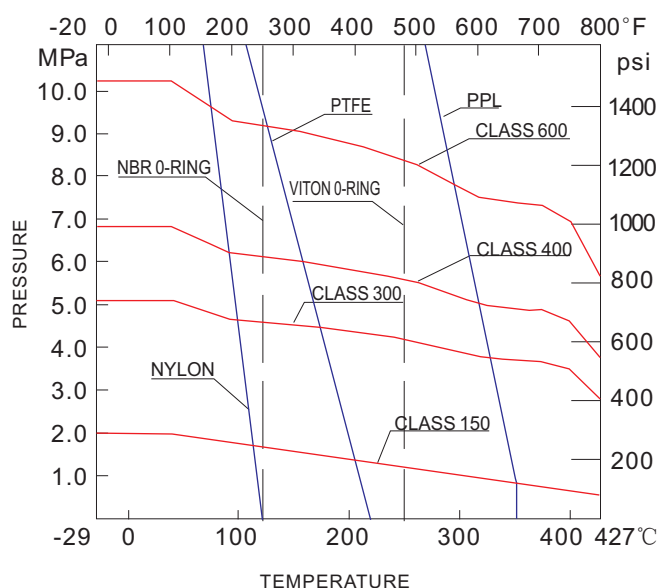

Note: The valve body material in the above chart is A105. For other P-T rating of different body material, please refer to ASME B16.34 (lasted edition)

GDR-2 TRUNNION MOUNTED BALL VALVE DYNAMIC DRAWING

**ROCKY UNION GDR-2 TYPE
API6D THREE PIECES FORGED BODY TRUNNION MOUNTED BALL VALVE
SIZE 16" - 42" PRESSURE 150# TO 2500#**

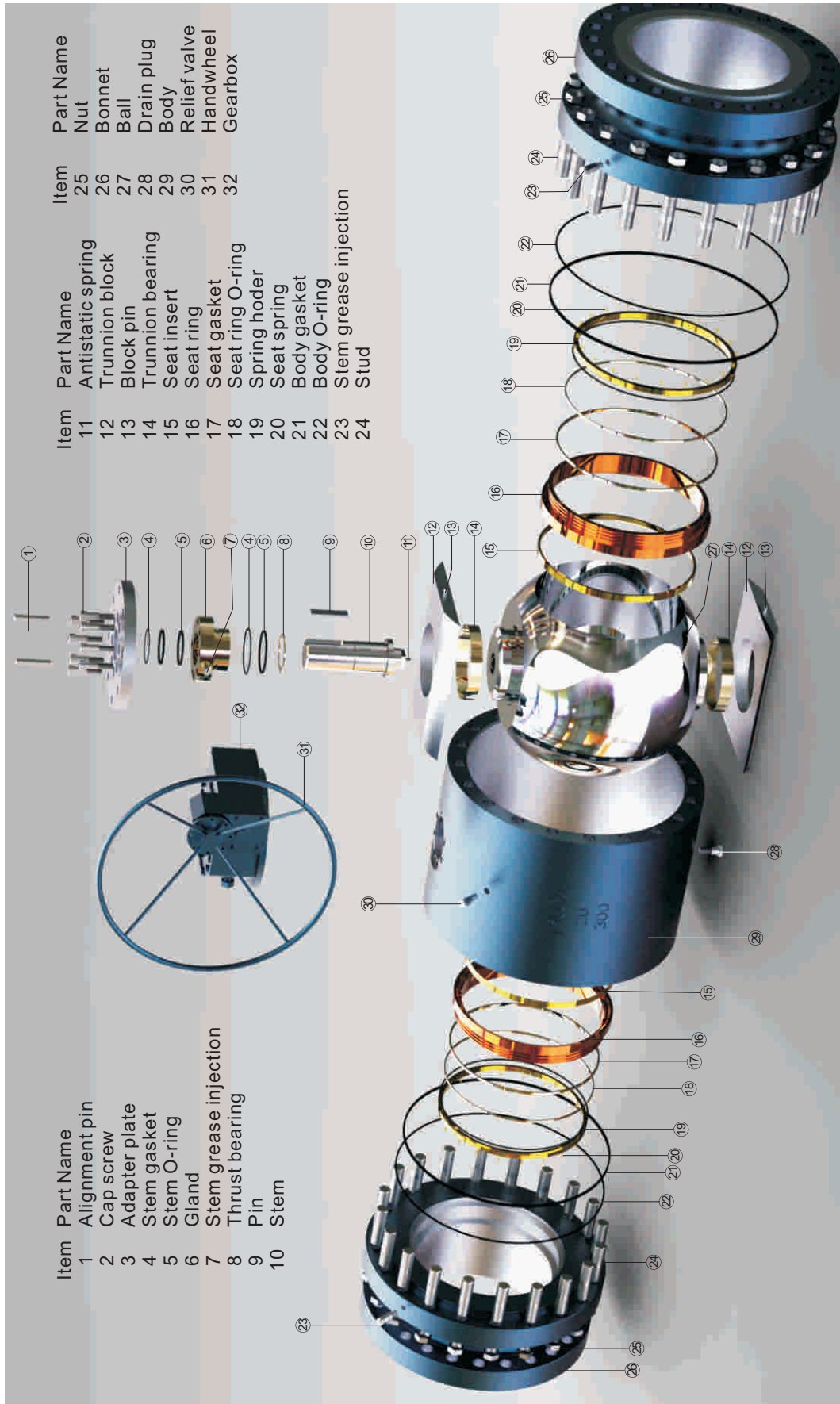

Item	Part Name
1	Alignment pin
2	Cap screw
3	Adapter plate
4	Stem gasket
5	Stem O-ring
6	Gland
7	Stem grease injection
8	Thrust bearing
9	Pin
10	Stem

Item	Part Name
11	Antistatic spring
12	Trunnion block
13	Block pin
14	Trunnion bearing
15	Seat insert
16	Seat ring
17	Seat gasket
18	Seat ring O-ring
19	Spring holder
20	Seat spring
21	Body gasket
22	Body O-ring
23	Stem grease injection
24	Stud

Item	Part Name
25	Nut
26	Bonnet
27	Ball
28	Drain plug
29	Body
30	Relief valve
31	Handwheel
32	Gearbox

GDR-2 TRUNNION MOUNTED BALL VALVE DIMENSIONS

GDR-2 TRUNNION MOUNTED BALL VALVE

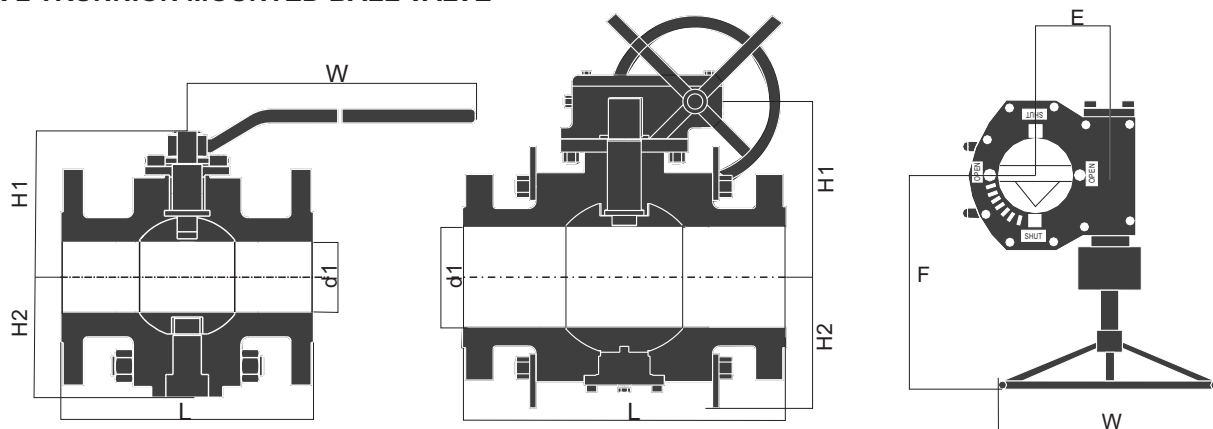

● **CLASS 150 Dimensions**

DN	2"	2 1/2"	3"	4"	5"	6"	8"	10"	12"	14"	16"	18"	20"	24"	28"	
d1	49	62	74	100	125	150	201	252	303	334	385	436	487	589	684	
L	RF	178	191	203	229	356	394	457	533	610	686	762	864	914	1067	1245
	BW	216	241	283	305	381	457	521	559	635	762	838	914	991	1143	1346
H1	80	80	100	115	184	260	300	325	365	400	440	500	555	700	780	
H2	150	150	200	240	300	340	389	405	455	490	550	620	680	870	955	
E	/	/	/	/	/	/	116	116	171	171	257	257	257	150	83	
F	/	/	/	/	/	/	350	350	420	420	400	400	400	410	650	
W	230	350	380	420	600	650	600	600	800	800	800	800	800	800	800	
Wt (kg)	13	16	25	40	60	80	216	350	480	580	870	1310	1600	3550	4500	

● **CLASS 300 Dimensions**

DN	2"	2 1/2"	3"	4"	5"	6"	8"	10"	12"	14"	16"	18"	20"	24"	28"	
d1	49	62	74	100	125	150	201	252	303	334	385	436	487	589	684	
L	RF	216	241	283	305	381	403	502	568	648	762	838	914	991	1143	1346
	BW	216	241	283	305	381	457	521	559	635	762	838	914	991	1143	1346
H1	80	80	100	115	184	260	300	325	365	400	440	500	555	700	780	
H2	150	150	200	240	300	340	389	405	455	490	550	620	680	870	955	
E	/	/	/	/	/	/	116	116	171	171	257	257	257	150	83	
F	/	/	/	/	/	/	350	350	420	420	400	400	400	410	650	
W	230	400	400	600	650	700	600	600	800	800	800	800	800	800	800	
Wt (kg)	15	24	30	55	90	120	260	375	540	640	1050	1550	2100	4200	5300	

● **CLASS 400 Dimensions**

DN	2"	2 1/2"	3"	4"	6"	8"	10"	12"	14"	16"	20"	24"	28"	
d1	49	62	74	100	150	201	252	303	334	385	487	589	684	
L	RF	292	330	356	406	495	597	673	762	826	902	1054	1232	1397
	BW	292	330	356	406	495	597	673	762	826	902	1054	1232	1397
H1	93	93	122	152	215	294	370	420	460	505	630	685	810	
H2	190	190	230	280	327	374	445	515	550	615	810	845	1010	
E	168	155	197	235	300	374	445	512	550	615	810	1010	1180	
F	/	/	/	/	116	171	171	257	257	257	150	83	123	
W	/	/	/	/	350	420	420	400	400	400	410	650	735	
Wt (kg)	23	35	49	95	195	360	640	890	1100	1540	2900	5300	5700	

GDR-2 TRUNNION MOUNTED BALL VALVE DIMENSIONS

GDR-2 TRUNNION MOUNTED BALL VALVE

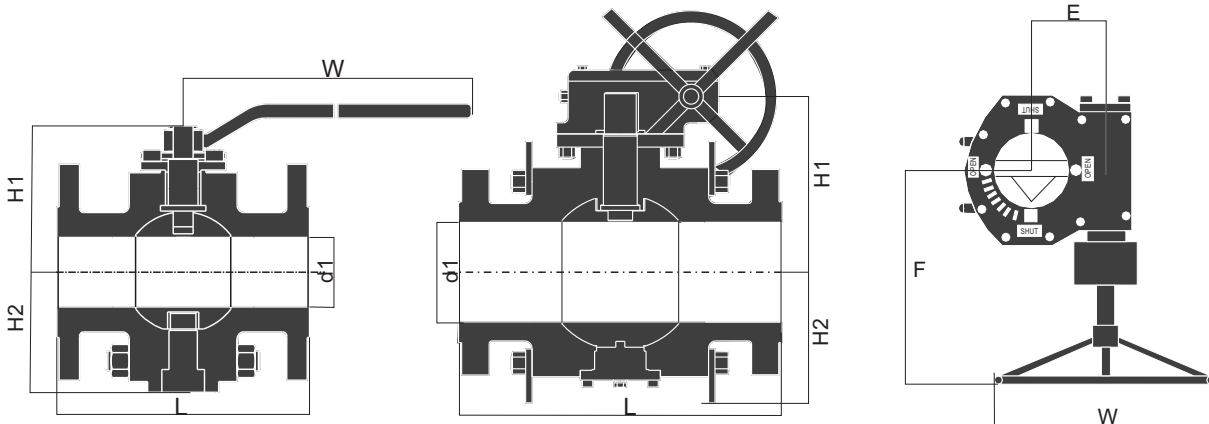

● **CLASS 600 Dimensions**

DN	2"	2 1/2"	3"	4"	6"	8"	10"	12"	14"	16"	20"	24"	28"
d1	49	62	74	100	150	201	252	303	334	385	487	589	684
L	RF&BW	292	330	356	432	559	660	787	838	889	991	1194	1549
	RJ	295	333	359	435	562	664	791	841	892	994	1200	1562
H1	93	93	122	152	215	294	370	420	460	505	630	825	970
H2	190	190	230	280	327	374	445	515	550	615	810	1010	1180
E	/	/	/	/	116	171	171	257	257	257	150	83	123
F	/	/	/	/	350	420	420	400	400	400	410	650	735
W	400	600	650	700	600	800	800	800	800	800	800	800	800
Wt(kg)	35	38	55	103	232	390	710	960	1700	1970	3250	5800	6700

● **CLASS 900 Dimensions**

DN	2"	2 1/2"	3"	4"	6"	8"	10"	12"	14"	16"	18"	20"	24"
d1	49	62	74	100	150	201	252	303	322	373	423	471	570
L	RF&BW	368	419	381	457	610	737	838	965	1029	1130	1219	1549
	RJ	371	422	384	460	613	740	841	968	1038	1140	1232	1569
H1	126	126	191	216	270	322	420	470	510	600	700	720	810
H2	217	217	259	297	360	394	502	572	675	762	866	894	956
E	/	116	116	116	171	171	257	169	42	42	72	72	91
F	/	350	350	350	420	420	400	573	696	696	745	745	830
W	650	600	600	600	800	800	800	700	700	700	700	700	700
Wt(kg)	50	60	80	125	270	440	770	1200	1800	2050	3000	3320	5950

● **CLASS 1500 Dimensions**

DN	2"	2 1/2"	3"	4"	6"	8"	10"	12"	14"	16"	18"	20"	24"
d1	49	62	74	100	144	192	239	287	315	360	406	454	546
L	RF&BW	368	419	470	546	705	832	991	1130	1257	1384	1537	2043
	RJ	371	422	473	549	711	841	1000	1146	1276	1407	1559	1972
H1	126	126	191	216	296	378	495	542	590	670	710	750	850
H2	217	217	259	297	365	475	578	696	761	831	900	950	1080
E	/	116	116	116	171	257	169	42	42	72	91	91	280
F	/	350	350	350	420	400	573	696	696	745	830	830	/
W	650	600	600	600	800	800	700	700	700	700	700	700	700
Wt(kg)	53	64	84	130	285	455	785	1280	1900	2150	3200	3400	6100

TRUNNION MOUNTED BALL VALVE C_v VALUE AND TORQUE

C_v VALUE

The following chart is the flow ratio of trunnion mounted ball valve.
 c_v indicates the gallons of water at temperature +60°F flowing through the valve bore in pressure differential down 1LBS/inch² (0.0068694757MPa).

SIZE	CLASS150	CLASS300	CLASS600	CLASS900	CLASS1500
2"	500	470	400	360	360
3"	1300	1100	1000	1000	900
4"	2300	2200	1800	1800	1600
6"	5400	5400	4500	4300	4000
8"	10000	10000	8900	8400	7900
10"	17800	17100	14500	14000	13000
12"	26000	25000	22000	21000	19000
14"	32000	31000	28000	26000	24000
16"	44000	42000	39000	36000	33000
18"	58000	56000	51000	47500	42000
20"	75000	72000	66000	60000	52000
24"	111200	102000	92000	86000	81000
26"	123000	108000	98000	91000	
28"	143000	123000	12200	112000	

RUV GDR TRUNNION MOUNTED BALL VALVE TORQUE

Size		Unit	Class 150		Class 300		Class 400		Class 600		Class 900	
DN	IN		Formula	Torque at 20 bar	Formula	Torque at 50 bar	Formula	Torque at 64 bar	Formula	Torque at 100 bar	Formula	Torque at 150 bar
150	6	N.m	176+7.36P	355	176+7.36P	612	176+7.36P	712	176+7.36P	1008	569+9.46P	2243
200	8		415+11.6P	712	415+11.6P	1095	415+11.6P	1272	415+11.62P	2395	982+24.93P	5125
250	10		500+19.1p	970	552+25.4p	2005	552+25.4p	2396	552+25.4p	3401	1318+30.6p	6657
300	12		901+33.8p	1735	901+33.8p	2851	901+33.8p	3370	901+33.8p	4752	2384+54.88p	12410
350	14		973+45p	2060	973+45p	7500	973+45p	4238	1287+61.7p	8155	2896+74.97p	16225
400	16		1582+77.3p	3441	1582+77.3p	5990	1582+77.3p	7182	1582+77.3p	11250	3789+103.4p	23410
450	18		1897+86p	3978	1897+86p	6816	1897+86p	8208	4907+97.3p	16220	4907+116.6p	25125
500	20		2385+108.8p	5017	2385+108.8p	7825	2385+108.8p	10355	5488+141.3p	23040	2385+108.8p	29965

1. This table of the torque is the valve breaking torque at maximum pressure differential, for choosing the operators.
2. Formula in the table can be used to calculate the stem torques at other pressure differential. Example: calculated stem torque of DN250, PN100 valve at 70bar pressure differential. The corresponding table can be used formula:552+25.4Xp, p=70, Torque=2330N.m
3. 50% Safety factor should be considered when choose the actuators.
4. All the datas above are just for reference. Contact RUV engineers to get actual datas.

TRUNNION MOUNTED BALL VALVE PIPE SIZE

CONNECTION PIPE INFORMATION

Pipe Description	Nominal Pipe Size(in.)						
	2	3	4	6	8	10	12
Outside Dia.(in.)	2.375	3.500	4.500	6.625	8.625	10.750	12.750
(STD)Standard	---	---	.237	.280	.322	.365	.375
Sch 40	.154	.216	.237	.280	.322	.365	.406
XS	.218	.300	.337	.432	.500	.500	.500
Sch 80	.218	.300	.337	.432	.500	.593	.687
Sch 160	.343	.438	.531	.718	.906	1.125	1.312
XXS	.436	.600	.674	.864	.875	1.000	1.000

Pipe Description	Size(in.)					
	14	16	18	20	22	24
Outside Dia.(in.)	14.000	16.000	18.000	20.000	22.000	24.000
(STD)Standard	.375	.375	.375	.375	.375	.375
Sch 40	.438	.500	.562	.593	---	.687
XS	.500	.500	---	---	.500	---
Sch 80	.750	.843	.937	1.031	1.125	1.218---
Sch 160	1.406	1.593	1.781	1.968	---	2.343
XXS	---	---	---	---	---	---

CONNECTION PIPE OUTSIDE DIA.(O.D)

Size(in.)	In.	mm
2	2.375	60.33
3	3.500	88.90
4	4.500	114.30
6	6.625	168.28
8	8.625	219.08
10	10.750	273.05
12	12.750	323.85
14	14.000	355.60
16	16.000	406.40
18	18.000	457.20
20	20.000	508.00
24	24.000	609.60

TRUNNION MOUNTED BALL VALVE TOP WORKS AND STEM TORQUE

RUV BALL VALVE TOP WORKS AND STEM TORQUE

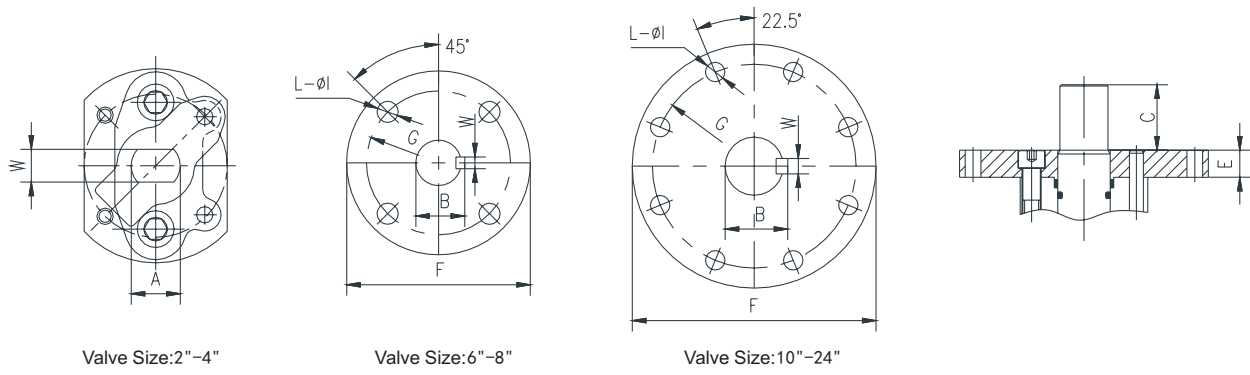

ANSI Class	Valve Size(in.)	A	B	C	E	F	G	I Hole Dia.	L No.of Holes	W	ISO5211 Mounting pad
150# 300#	2 "	0.787	----	1.496	0.394	3.622	----	----	----	----	F07
	3 "	1.024	----	1.89	0.63	3.622	----	----	----	----	F07
	4 "	1.339	----	1.89	0.787	4.921	----	----	----	----	F10
	6 "	1.732	----	3.307	1.299	6.69	5.512	0.748	4	1.063	F14
	8 "	1.969	----	2.598	1.732	8.268	6.496	0.906	4	0.551	F16
	10 "	1.969	2.106	2.598	0.984	8.268	6.496	0.906	8	0.551	F16
	12 "	2.52	2.74	3.268	1.201	11.811	10	0.748	8	0.709	F25
	14 "	2.52	2.74	3.268	1.299	11.811	10	0.748	8	0.709	F25
	16 "	2.953	3.173	4.522	1.299	11.811	10	0.748	8	0.787	F25
	18 "	2.953	3.173	4.522	1.299	11.811	10	0.748	8	0.787	F25
	20 "	3.346	3.646	4.522	1.575	11.811	10	0.748	8	0.945	F25
	24 "	3.937	4.276	5.433	1.417	13.78	11.732	0.906	8	1.102	F30

TRUNNION MOUNTED BALL VALVE TOP WORKS AND STEM TORQUE

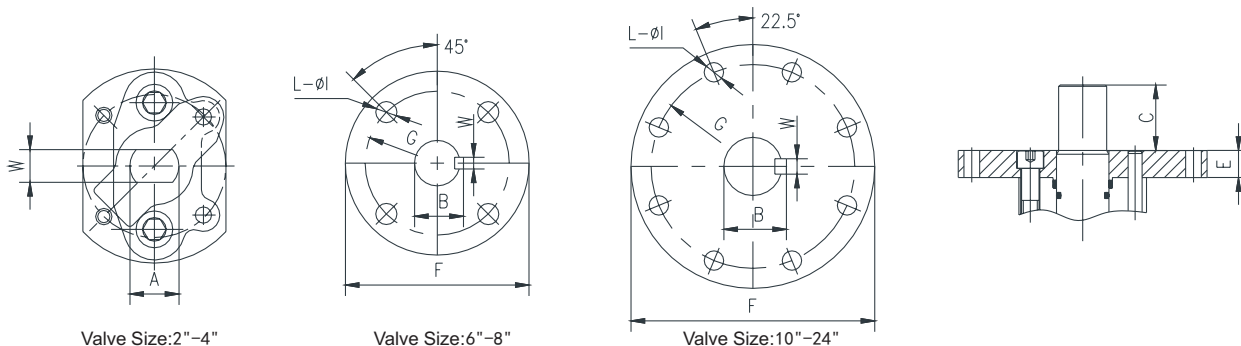

Valve Size:2"-4"

Valve Size:6"-8"

Valve Size:10"-24"

ANSI Class	Valve Size(in.)	A	B	C	E	F	G	I Hole Dia.	L No.of Holes	W	ISO5211 Mounting pad
600#	2 "	1.024	----	1.89	0.394	3.543	2.756	0.315	4	0.669	F07
	3 "	1.339	----	1.89	0.394	4.646	4.016	0.394	4	0.866	F10
	4 "	1.732	----	3.346	1.22	6.89	5.512	0.748	4	1.063	F14
	6 "	1.969	----	2.598	1.299	8.268	6.496	0.906	4	0.551	F16
	8 "	2.52	2.74	3.346	1.732	11.811	10	0.748	4	0.709	F25
	10 "	2.52	2.74	3.346	0.984	11.811	10	0.748	8	0.709	F25
	12 "	2.953	3.173	4.252	1.319	11.811	10	0.748	8	0.787	F25
	14 "	2.953	3.173	4.252	1.299	11.811	10	0.748	8	0.787	F25
	16 "	3.346	3.646	4.252	1.299	11.811	10	0.748	8	0.945	F25
	18 "	3.937	4.276	5.433	1.299	13.811	11.732	0.906	8	1.102	F30
	20 "	3.937	4.276	5.433	1	13.78	11.732	0.906	8	1.102	F30
24 "	4.724	5.102	7.48	2.362	13.78	14.016	1.299	8	1.26	F35	
900#	2 "	1.339	----	1.89	0.394	4.724	4.016	0.394	4	0.866	F10
	3 "	1.732	----	3.346	0.394	6.89	5.512	0.784	4	1.063	F14
	4 "	1.969	----	2.598	1.22	8.268	6.496	0.906	4	0.551	F16
	6 "	1.969	----	2.598	1.378	8.268	6.496	0.906	4	0.551	F16
	8 "	2.52	2.74	3.346	1.575	11.811	10	0.748	8	0.709	F25
	10 "	2.953	3.173	4.252	1.26	11.811	10	0.748	8	0.787	F25
	12 "	3.346	3.646	4.522	1.811	11.811	10	0.748	8	0.945	F25
	14 "	3.937	4.276	5.433	1.378	13.78	11.732	0.906	8	1.102	F30
	16 "	3.937	4.276	5.433	1	13.78	11.732	0.906	8	1.102	F30
1500#	2 "	1.339	----	1.89	1.102	4.724	14.016	0.394	4	0.866	F10
	3 "	1.969	----	2.598	1.181	8.268	6.496	0.906	4	0.511	F16
	4 "	1.969	----	2.598	1.22	8.268	6.496	0.906	4	0.511	F16
	6 "	2.52	----	3.346	1.181	11.811	10	0.748	8	0.709	F25
	8 "	2.953	3.173	4.522	1.575	11.811	10	0.748	8	0.787	F25
	10 "	3.346	3.646	4.522	1.457	11.811	10	0.748	8	0.945	F25
	12 "	3.937	4.276	5.433	1.811	13.78	11.732	0.906	8	1.102	F30

TRUNNION MOUNTED BALL VALVE TEST PROCEDURE

ROCKY UNION TRUNNION MOUNTED BALL VALVE TEST PROCEDURE

HYDROSTATIC SEAL TEST API6D 10.3 and 10.4						
Sequence		Area Pressure		Duration(min)		Description
SHELL TEST		A	1.5x PN	6 " -10 "	5	1. Valve in partial open. 2. Set the pressure to 150% PN. 3. Reduce the pressure to 50% PN. 4. Reset the pressure to 150% PN. 5. Hold the pressure for the duration of testing.
		B	1.5xPN	12 " -18 "	15	
		C	1.5xPN	20 " -60 "	30	
SEAT TEST		A	1.1xPN	5	5	Seat hydro seal test at A end towards body B
		B	Atmospheric			
		C	Atmospheric			
		A	Atmospheric	5	5	Seat hydro seal test at C end towards body B
		B	Atmospheric			
		C	1.1xPN			
		A	1.1xPN	5	5	Seat hydro seal test for both A and C DBB
		B	Atmospheric			
		C	1.1xPN			
AIR SEAL TEST API6D 10.4						
SEAT TEST		A	Atmospheric	5	5	Seat air seal test at A end towards body B
		B	Atmospheric			
		C	80PSIG(5.5bar)			
		A	80PSIG(5.5bar)	5	5	Seat air seal test at C end towards body B
		B	80PSIG(5.5bar)			
		C	Atmospheric			

PN= Nominal Pressure Blue=Liquid Yellow=Air

HOW TO SPECIFY RUV BALL VALVES

TYPE

FDR1---Floating cast body ball valve
 FDR2---Floating forged body ball valve
 GDR1---Trunnion mounted cast body ball valve
 GDR2---Trunnion mounted forged body ball valve
 GDR3---Fully welded body ball valve
 GDR4---Top entry ball valve

PRESSURE CLASS

15---Class 150 30---Class 300
 60---Class 600 90---Class 900
 150---Class 1500 250---Class 2500

END

RJ---Ring joint BW---Butt weld
 RF---Raised face

SEAT

01---TEFLON 02---PTFE 03---NYLON
 04---PEEK 05---PPL 06---DEVLON
 07---VITON 08---STELLITE
 09---TUNGSTEN COATED

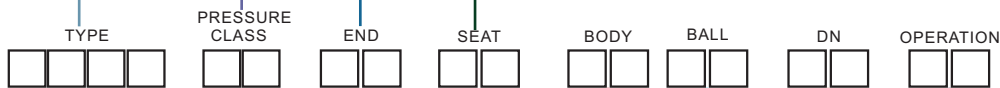

BODY MATERIAL

C1---WCB C2---WCC C3---LCC C4---LCB
 C5---CF8 C6---CF8M C7---WC6 C8---WC9
 A1---A105 A2---F304 A3---F316 A4---LF2
 A5---F51

BALL

B1---105+ENP B2---316 B3---304
 B4---LF2+ENP B5---105+HCr
 B6---TUNGSTEN COATED B7---F51

NOMINAL SIZE

F ---Full port R ---Reduced port
 01---1" 02---02" 10---10" 12---12" etc

OPERATION

0 Lever 1 Bare stem 2 Gear
 3 Electric 4 Hydraulic 5 Pneumatic
 6 Gas over oil P Operation

EXAMPLES

F D R 2 1 5 R F 0 4 A 1 B 1 F 02 P 0

Forged body floating ball valve, Class 150, Raised face, with seat of PEEK and body materials constructed using A105, Ball constructed with 105+ENP, full port, nominal size 2 inch, operated by lever.

G D R 2 6 0 R J 0 2 A 1 B 3 F 08 P 2

Forged body trunnion mounted ball valve, Class 600, Ring joint, with seat of PTFE and body materials constructed using A105, Ball constructed with materials of 304, Full port, nominal size 8 inch, operated by gearbox.

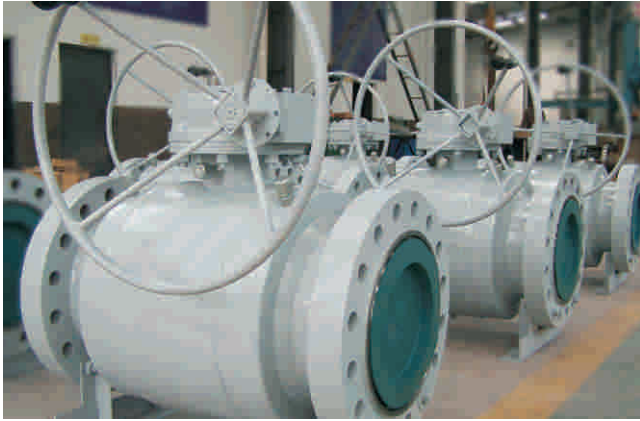

WE MAKE FOR RELIABILITY

ROCKY UNION VALVE CO.,LTD

Address: Chuannan SME Incubator, Bancang Industrial Park Hi-Tech
Development Area Zigong City, Sichuan People's Republic of China
Tel:+86-813-5536058 Fax:+86-813-5519412
E-mail: sales@rockyunion.com
rockyvalve@163.com
Website: www.rockyunion.com

Special Statement

ROCKY UNION is always committed to provide high quality products and efficient service to our customers, At the same time, we have always strictly abided by the provisions of the state; abided by the relevant international rules. And we also abide by the business and professional ethics, making effort to providing employees safety, healthy, environmental work environment.